

Rail fastening system for slab tracks

System DFF 21

System DFF 21 with tension clamp Skl 21

Highly elastic rail fastening system as single support point with a screw/dowel combination to be anchored in the substructure of mainline or metro tracks.

FEATURES

- Skl 21 tension clamp with 2.5 mm fatigue strength
- Gauge adjusts ± 10 mm with angled guide plates
- Highly elastic intermediate pads with stiffnesses of > 50 kN/mm for ample subsidence
- Height adjustment possible
- Simple installation
- Installation in turnouts possible
- Installation in covered tracks possible
- Rail tilting protection by middle bend of the tension clamp and specially designed angled guide plate
- High electric insulation

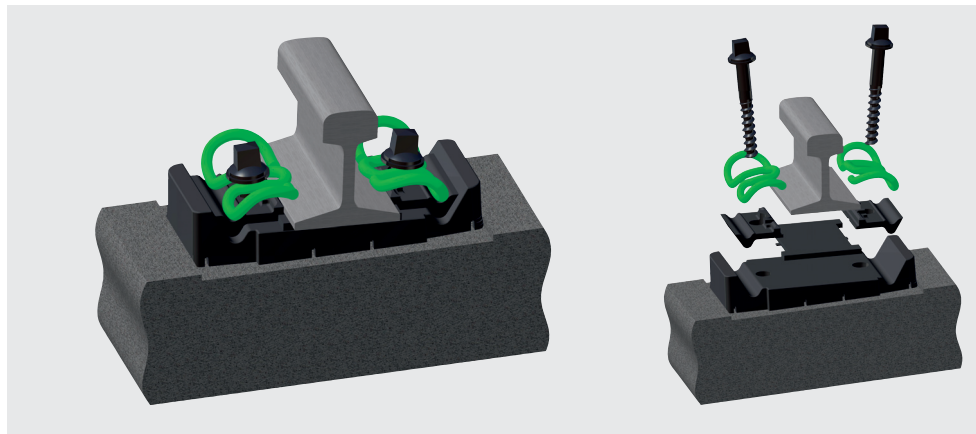

System DFF 21

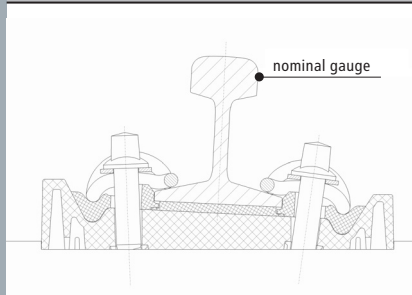

Load/spring deflection of tension clamp Skl 25

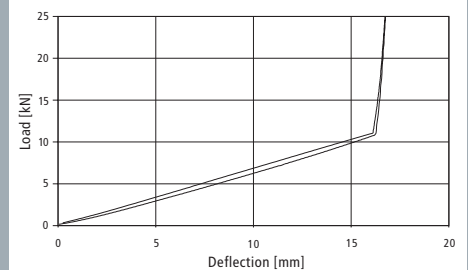

Vossloh Fastening Systems GmbH
P.O. Box 18 60
D-58778 Werdohl
Phone +49 (0) 23 92/52-0
Fax +49 (0) 23 92/52-375
info@vfs.vossloh.com